

SPA101

Type 2 Surge Arrester

The SPA101 is for installation at LPZ 0_B-1 or higher, protecting low voltage equipment from surge damage. Designed according to IEC 61643-11/GB 18802.1. This device has a pluggable modular SPD Class II (Class C) TN and TT power supply systems.

According to the lightning protection zones concept, this device is for installation at LPZ 0_B-1 or higher. This surge protective device is usually installed in the distribution-box or feeder bus of the UPS, protecting devices or equipment downstream.

A fuse must be installed at the upstream of the SPD / lightning arrester to make sure that the protected system has double protection.



SPA101

Internal Wiring

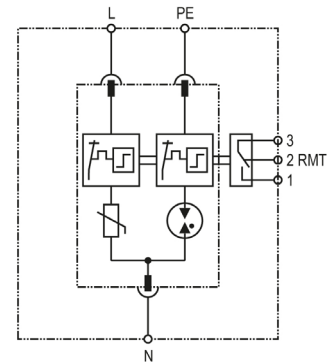

Specification		
Nominal a.c. voltage	U_N	230VAC
Rated voltage (max. continuous voltage)	U_C	275V (L-N); 255 (N-PE)
Nominal discharge current (8/20)	I_n	20kA (L-N); 40kA (N-PE)
Max. discharge current (8/20)	I_{max}	40kA (L-N); 65kA (N-PE)
Voltage protection level at I_n	U_p	$\leq 1.25kV$ (L-N); $\leq 1.5kV$ (N-PE)
Voltage protection level 5kA	U_p	$\leq 1.0kV$ (L-N)
Response time	t_A	$\leq 25ns$ (L-N); $\leq 100ns$ (N-PE)
Max. back up fuse		125A gL/gG
Operating temperature range	T_U	-40°C to +80°C
Cross-sectional area (L/N)		1.5mm ² - 10mm ² solid/flexible
Cross-sectional area (PE)		6mm ² - 25mm ² solid/flexible
Connection type		Screw Terminal
Mounting on		35mm DIN rail
Enclosure material		Light grey Thermoplastic, UL94-V0
Test standards: EN 61643-11; IEC 61643-11; GB 18802.1; YD/T 1235.1		TYPE 2 - CLASS II
Certification		CE (LVD, EMC)
Type of remote signalling contact		Switching contact
Switching capacity	U_N / I_N	AC:250V/0.5A DC:250V/0.1A, 125V/0.2A, 75V/0.5A
Cross-sectional area for remote signalling contact		Max. 1.5mm ² solid / flexible
Part Code		SPA101

Installation

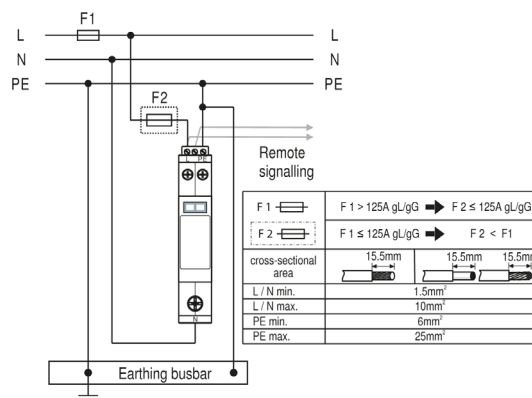

Revision: ANW-v3, 16/07/19
Information subject to change without notice.

All of the above information, including drawings, illustrations and graphic designs, reflects our present understanding and is to the best of our knowledge and belief correct and reliable. Users, however, should independently evaluate the suitability of each product for the desired application.

